



Redwood Valley County Water District

Post Office Box 399 • Redwood Valley, CA 95470 • (707) 485-0679

PART II
General Manager's Report
+ Grant Deed
(Inteptic Related)

AGENDA BOARD OF DIRECTORS

Regular Meeting

Time: 7:00 p.m.

Date: Thursday, August 21, 2014

Location: District Office, 2370 Webb Ranch Road, Redwood Valley, California.

Expected Guests:

- All items listed below are considered action items unless otherwise noted.
- The items listed below are numbered for convenience only and may not necessarily be heard in this order.

1. Roll Call.
2. Hearing of comments or questions from the attending public.
See end of Agenda for information regarding public comments.
3. Consider hearing of urgent items received since the Agenda was posted.
See end of Agenda for information regarding the hearing of urgent items.
4. Acceptance of Agenda.
5. Approval of Consent Calendar.
 - a. Financial Statement.
 - b.-1. Bills Paid since those approved at last Meeting.
 - b.-2. Bills Paid as approved at previous Meeting.
 - c. Bills Payable.
 - d. District Activity.
6. Approval of Minutes as presented.
7. Directors and Staff reports and discussion of non-action topics.
 - a. Personnel Committee Report.
 - b. Ad Hoc/Consolidation Committee Report.
 - c. Discussion of rates.

BOARD OF DIRECTORS

Granville Pool
Pamela Ricetti
Ken Todd
Jeff Basili

8. General Manager's Report and Action Items.
 - A. District Operations.
 - B. New Board Member.
 - C. Recording Secretary.
 - D. Intertie/Pump Station.
 - E. Water Usage.
 - F. Budget.
 - G. School Way.
 - H. ACWA Update.
 - I. LAFCo.
 - J. JPA.
 - K. Monitoring Well.
9. Financial Report.
 - a. Discussion and possible action.
10. Local Agency Formation Commission of Mendocino County – LAFCO.
 - a. Discussion and possible action on LAFCO topics.
11. M. C. Inland Water & Power Commission.
 - a. Report of attendance at IW&PC Meetings.
 - b. Consider any correspondence concerning the IW&PC.
 - c. Discussion and possible action on IW&PC topics.
12. Mendocino County Russian River Flood Control & Water Conservation Improvement District.
 - a. Report of attendance at MCRRFC&WCID meetings.
 - b. Consider any correspondence concerning the MCRRFC&WCID.
 - c. Discussion and possible action on Flood Control District topics.
13. Sonoma County Water Agency.
 - a. Consider any correspondence or reports concerning the Sonoma County Water Agency.
 - b. Discussion and possible action.
14. Report of attendance at agency meetings, i.e. City of Ukiah, County Board of Supervisors, other Special District's, County of Mendocino departments, or other entity not listed separately herein.
15. State Water Resources Control Board.
 - a. Updates and possible action.
16. Status report of Place of Use issues.
 - a. Updates and possible action.
17. Status report of 2800 acre-feet Storage Right.
 - a. Updates and possible action.

18. Consider attendance at seminars, training events, conferences as received since last Meeting.

POSTED: 8/15/14

Public Comments

Comments will be limited to matters under this District's jurisdiction that are not on the posted agenda and items that have not been previously considered by the Board of Directors.

Comments on a matter not on the agenda are limited to three (3) minutes per person and not more than ten (10) minutes for a particular subject.

No action will be taken. Individuals wishing to address the Board are welcome to do so throughout the Meeting.

Urgent Items

In accordance with Section 54954.2 (b)(2) of the Government Code Brown Act, Two-thirds Vote Required for Action Items. (Upon determination by a two-thirds vote of the legislative body, or, if less than two-thirds of the members are present, unanimous vote of those members present, that the need to take action arose after the Agenda was posted.)

ADA Compliance

The Redwood Valley County Water District complies with ADA requirements and will attempt to reasonably accommodate individuals with disabilities upon request. To assist us in better understanding your request, please notify the District Office no less than 3 working days in advance of the meeting by calling (707) 485-0679.

REDWOOD VALLEY COUNTY WATER DISTRICT
GENERAL MANAGER'S REPORT
AND ACTION ITEMS
AUGUST 21, 2014

AGENDA ITEM. NO 8

- A. District Operations. The district is operating well with no particular problems to report. Drought and budget issues will be discussed as separate topics.
- B. New Board Member. Hal Voegel is the only person who has submitted a statement of interest for the vacant Board position. If any others come in before the Board meeting, I will submit them to the Board. Candidates may also apply at the Board meeting. The vacancy was effective June 20 so the appointment needs to be made at this Board meeting or the authority to appoint passes to the Board of Supervisors.
- C. Recording Secretary. We still have not found a new recording secretary. Our new employee stated that his wife might be interested. Unfortunately she cannot attend our meeting in person due to a conflict. She has been working with the recorded meetings for June and July. If the Board is satisfied with the minutes it may wish to consider appointing Jeanette Wise to the position of recording secretary. The previous fee paid was \$25/hour. Water Code §30579 defines the duties of the secretary primarily to attest documents or co-sign contracts. Paula can continue to provide these services. Water Code does not specify that the recording secretary has to attend in person. If the arrangement to have her transcribe the voice files is acceptable we should consider investing in a better recording device, possibly with at least one remote microphone for the audience. **Discuss and possibly approve appointing Jeanette Wise as recording secretary.**
- D. Intertie/pump station. There was a brief delay with the easement for the pump building. This has been largely resolved. The property will be a fee simple transfer to the district rather than an easement. This eliminates any liability to the original owner of the property. Director Pool is taking the lead on this item to make sure that all property transfer issues are being handled properly. **The Board needs to approve accepting the Grant Deed and needs to authorize the Board President to sign the accompanying documents.** Our engineering firm is coordinating with Millview's engineering firm to ensure that the intertie will be finished in time to receive water from Millview. The good news is that the grant approval is now complete and we can start requesting reimbursement.
- E. Water usage. Our water usage is greater than projected, largely due to a population larger than originally estimated. The initial estimate was based on 1350 equivalent dwelling units with an occupancy rate of 2.8 people per dwelling. Per this calculation the population is estimated at ~ 4000. We are getting reports that it is considerably higher than that, possibly double. It is fortunate that the allowed amount was lowered from 80 gallons per person to 50 gallons or we

would already be out. It is likely that we will have exhausted the 355 AF by mid October. The goal is to have the intertie active by that date.

Excessive users continue to be a problem. Fortunately most of our customers are keeping within the allowed usage. Those who do not fall into several categories. There are people who are willing to pay the penalty to maintain expensive, established landscapes. Most of them are cooperating after being contacted by at least letting their lawns go without watering. There are also a few customers who fall into a miscellaneous category. These are people who had leaks, or who for a variety of reasons had a much larger number of people for a limited period of time. The last category is the pot growers. I spoke with Lake County Special Districts regarding their drought ordinance which does allow termination of service. They do not cite specific Case Law, but instead cite their own ordinance which was passed after public review. Unfortunately that is a time consuming process and we are unlikely to be able to put anything into place prior to the end of the outdoor growing season. Clearly this is something we need to look at for the future. The Special District coordinator did state that, like us, they are discovering things that are wrong with their ordinance now that they are actually implementing it.

- F. Budget. The budget is not only late; it is a matter of concern. I have cut out virtually all capital projects except a few that have been approved for past budget years. We are expecting a greatly reduced revenue stream both for agricultural water and for domestic water. The amount we are receiving in penalties is relatively insignificant compared to lost revenue due to reduced consumption. We continue to receive regular payments from our irrigation customers but this is at a much lower amount than it would be if they had free access. This lowered revenue will continue through this irrigation season and will also potentially impact the next frost season as we credit water not delivered this year. A number of previously approved items must be paid for despite lack of revenue. These include the School Way Bridge project, upgrades to the radio link with the lake pumps and tanks, the independent Lake Mendocino yield study, LAFCo annexation review, and the Clearwell repair. We cannot predict a balanced budget this fiscal year and must deplete capital reserves to complete the bare minimum of projects. **Discuss and possibly approve the FY 2014-2015 budget.**

- G. School Way. The School Way Bridge project has been awarded to MCM Construction. (Noyo River Bridge, Confusion Hill Bridge, etc.) The Bid Additive for our water line replacement is not the lowest bid for that item. Our engineer (Rau and Associates) has reviewed the bid and recommends we accept it. **Discuss and possibly approve Additive Bid from MCM Construction.** Construction will start very soon. Although the majority of the financial impact to Redwood will occur next year, there may be some costs that will come due this year. There may be a significant charge to Redwood later this fiscal year depending on their construction schedule.

- H. ACWA update. Katie Dahl from ACWA has asked to present a brief update regarding that organization. As a courtesy to Ms. Dahl please consider moving this item forward.

- I. LAFCo. LAFCo has approved an initial review of the dissolution/annexation document. This should provide information on how to proceed. Initial finding was agreed upon some months ago.

- J. JPA. A draft JPA proposal (May 2014) for a consolidation of RV, Millview and Willow has recently been circulated and seems to be causing some concern to others. This draft was prepared without input from the districts and has not been approved or signed by any of the districts. The affected districts will be meeting as soon as can be arranged to discuss what would be appropriate to move ahead with some form of combining the various county water districts primarily for operational purposes. The meeting will be limited to General Managers and Board Presidents.

- K. Monitoring well. This is a place holder for any new information regarding the well that may arise.

AGENDA ITEM NO. 8b.

To the Board of Redwood Valley County Water District:

This is my application to the Board to serve out Jeanette Hallman's unexpired term. Being a Board member is a job that requires work beyond attending monthly board meetings. I am willing to do this job because I believe it is important work

I have been actively involved with this Water Board, as a member of the public and, for five years, as a Board member. I worked: to raise awareness during periods of water scarcity, to set our priorities wisely, and to keep customers informed. With that experience, years of public and community relations experience, and my continuing interest, I would be able to take an active part in the work of the board without a lengthy learning curve.

While I was on the Board, we did a customer survey that got a substantial response. One of the main points the customers made was that they wanted a reliable supply of water. I'm sure that is still very important to them. Now, the Board needs to work out how to make that happen without jeopardizing either the agricultural producers, who generate much revenue for this community, or the less wealthy residential customers. All options should be on the table. They must be carefully evaluated because "the devil is always in the details".

As a Board member, I attended meetings of other boards and agencies such as - the Board of Supervisors, the Millview Board and the Eel Russian River Commission, and brought back what I learned. I would do that again. This "cross fertilization" is important. It is also important that all the water agencies in this part of the Russian River watershed develop the ability to speak to outside agencies and groups "with one voice" as much as possible.

I continue to be involved with IWPC and with the outreach effort to make people in the Russian River watershed appreciate how important the water coming from the Eel through the Potter Valley Project is to us all.

Hal Voege

AGENDA ITEM NO. 8d.

**RECORDED AT THE REQUEST OF
AND WHEN RECORDED RETURN TO:**

Richard Ingram
Brelje & Race Engineers
475 Aviation Blvd. Suite 120
Santa Rosa, CA 95403

Transfer Tax Not Applicable: R&T Code 11922
Exempt from Recording Fees: Gov. Code 27383

APN 165-150-23

Space above this line for Recorder's use only

CERTIFICATE OF ACCEPTANCE

GRANT DEED

Pursuant to California Government Code Section 27281, this is to certify that the interest in real property conveyed by the deed or grant dated _____, 2014 from Gregory D. Mathis and Susan M. Mathis, Trustees of the Mathis Family Revocable Living Trust to the Redwood Valley County Water District, a political subdivision of the State of California, is hereby accepted by order of the Board of Directors of the Redwood Valley County Water District on _____, 2014, and the grantee consents to the recordation thereof.

Dated _____

BY: _____

President of the Board of the Redwood Valley County Water
District

ATTEST:
District Secretary

By: _____

RECORDING REQUESTED BY
Redwood Valley County
Water District

AND WHEN RECORDED MAIL DOCUMENT AND
TAX STATEMENT TO:

NAME Richard Ingram
STREET ADDRESS Brelje & Race Engineers
475 Aviation Blvd.
CITY, STATE & ZIP CODE Suite 120
Santa Rosa, CA
95403

TITLE ORDER NO.

ESCROW NO.

SPACE ABOVE THIS LINE FOR RECORDER'S USE ONLY

Exhibit A
GRANT DEED

APN: 165-150-23

The undersigned grantor(s) declare(s) _____
DOCUMENTARY TRANSFER TAX S
 computed on full value of property conveyed, or
 computed on full value less liens and encumbrances remaining at time of sale.
 Unincorporated Area City of _____

FOR VALUABLE CONSIDERATION, receipt of which is hereby acknowledged, I (We)
Gregory D. Mathis and Susan M. Mathis, Trustees of the Mathis Family
Revocable Living Trust
hereby remise, release and grant to
Redwood Valley County Water District

the following described real property in the City of _____, County of Mendocino
State of California, with the following legal description:

As described in Exhibit "B" and as shown on Exhibit "C" attached
hereto and made a part hereof.

_____ Date

_____ Gregory D. Mathis

_____ Susan M. Mathis

STATE OF _____

COUNTY OF _____

On _____ (Date) before me, _____ (Name and title of the officer)

personally appeared _____ (Name of person signing), who proved to me on the basis of
satisfactory evidence to be the person(s) whose name(s) is/are subscribed to the within instrument and acknowledged to me that
he/she/they executed the same in his/her/their authorized capacity(ies), and that by his/her/their signature(s) on the instrument the
person(s), or the entity upon behalf of which the person(s) acted, executed the instrument.

I certify under PENALTY OF PERJURY under the laws of the State of California that the foregoing paragraph is true and correct.

WITNESS my hand and official seal.

Signature of officer

(Seal)

MAIL TAX STATEMENT AS DIRECTED ABOVE

EXHIBIT B
PUMP STATION PARCEL

ALL THAT REAL PROPERTY SITUATED IN THE COUNTY OF MENDOCINO, STATE OF CALIFORNIA, AND BEING A PORTION OF THE LAND OF THE MATHIS FAMILY REVOCABLE LIVING TRUST UNDER DECLARATION DATED SEPTEMBER 7, 1995, AS DESCRIBED BY DEED RECORDED AS DOCUMENT NUMBER 1996-00002471, OFFICIAL RECORDS OF MENDOCINO COUNTY, DESCRIBED AS FOLLOWS:

COMMENCING AT A FOUND 1" IRON PIPE MARKING THE SOUTHERLY TERMINUS OF THE COURSE LABELED SOUTH 14°16'00" WEST 50.00 FEET AS DESCRIBED IN THAT CERTAIN GRANT DEED FROM GREGORY D. MATHIS AND SUSAN MATHIS, HUSBAND AND WIFE TO THE STATE OF CALIFORNIA RECORDED IN BOOK 1517 OFFICIAL RECORDS PAGE 297 OF THE MENDOCINO COUNTY RECORDS, BEING A POINT ON A CURVE CONCAVE TO THE SOUTH HAVING A RADIUS OF 45.00 FEET TO WHICH A RADIAL LINE BEARS NORTH 05°00'35" WEST; THENCE ALONG THE EASTERLY BOUNDARY LINE OF THE SAID LANDS OF MATHIS WESTERLY ALONG SAID CURVE THROUGH A CENTRAL ANGLE OF 28°02'39" AN ARC LENGTH OF 22.03 FEET TO THE TRUE POINT OF BEGINNING OF THE PARCEL HEREIN DESCRIBED; THENCE CONTINUING ALONG SAID BOUNDARY ALONG SAID CURVE IN SOUTHWESTERLY DIRECTION THROUGH A CENTRAL ANGLE OF 33°33'55" AN ARC LENGTH OF 26.36 FEET; THENCE LEAVING SAID EASTERLY BOUNDARY LINE NORTH 75°57'02" WEST 9.40 FEET; THENCE NORTH 14°02'58" EAST 23.33 FEET; THENCE SOUTH 75°57'02" EAST 20.84 FEET TO THE POINT OF BEGINNING.

CONTAINING 319 SQUARE FEET, MORE OR LESS.

APN: 165-150-23

DATE: July 24, 2014

PREPARED BY: BRELJE & RACE, CONSULTING ENGINEERS

JOB NO.: 983.09



R1 BOOK 1517 OR PAGE 297
 POC POINT OF COMMENCEMENT
 POB POINT OF BEGINNING

LANDS OF MATHIS FAMILY
 REVOCABLE LIVING TRUST
 APN 165-150-23
 DOC NO. 1996-00002471

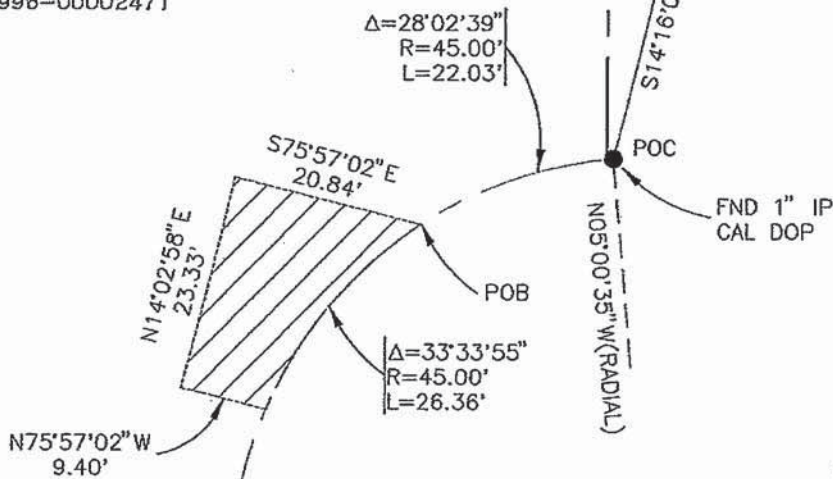

LANDS OF STATE OF CALIFORNIA
 BOOK 1517 OR PAGE 297

CENTRAL AVE

THIS EXHIBIT IS FOR GRAPHIC PURPOSES ONLY. ANY ERRORS OR OMISSIONS ON THIS EXHIBIT SHALL NOT AFFECT THE DEED DESCRIPTION.

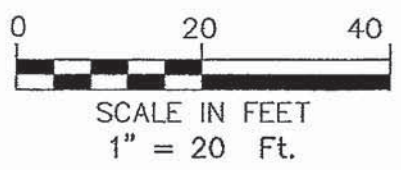

John S. Locey
 JOHN SIDNEY LOCEY RCE 31909

EXHIBIT C

**PUMP STATION
 PARCEL**

OWNER: MATHIS FAMILY REVOCABLE LIVING TRUST
 6704 CENTRAL AVENUE
 UKIAH, CA 95482-9546

DOC NO. 1996-00002471 APN 165-150-23

PREPARED BY

Brelje & Race
 CONSULTING CIVIL ENGINEERS
 473 S. Capitol Blvd. - Suite 300 - Santa Ana, CA 92701-7078
 www.brelje.com

07-24-14 blm/hrs \983\mpsp\983 R-resect.dwg TAB: Layout1

RESOLUTION NO. _____

**A RESOLUTION OF THE BOARD OF DIRECTORS OF
THE REDWOOD VALLEY COUNTY WATER DISTRICT
AUTHORIZING ACCEPTANCE OF GRANT DEED**

REDWOOD VALLEY COUNTY WATER DISTRICT

RESOLVED, by the Board of Directors of the **REDWOOD VALLEY COUNTY WATER DISTRICT**, Mendocino County, California, that this Board does hereby accept that certain grant deed executed by Gregory D. Mathis and Susan M. Mathis, Trustees of the Mathis Family Revocable Living Trust, of Mendocino County, California, attached hereto as **Exhibit "A"** and made a part hereof, conveying to said District permanent rights of ownership regarding referenced parcels of land for the purpose of constructing a water system pump house.. Said grant deed together with a certificate of acceptance will be filed by the District secretary in the office of the Recorder of the County of Mendocino, State of California, that being the county in which said lands are located.

I hereby certify that the foregoing is a full, true, and correct copy of a Resolution duly and regularly adopted and passed by the Board of Directors of the **REDWOOD VALLEY COUNTY WATER DISTRICT**, Mendocino County, California, at the meeting thereof adjourned on the ___ day of August, 2014, by the following votes:

- AYES, in favor thereof, Directors:
- NOES, Directors
- ABSENT, Directors

Secretary

APPROVED:

Bill Koehler

From: Granville [teacupfarm@comcast.net]
Sent: Monday, August 11, 2014 3:52 PM
To: 'Bill Koehler'
Subject: Subdivision Map Act Exemption

Thanks to Howard:

Subdivision Map Act:

66428. (a) Local ordinances may require a tentative map where a parcel map is required by this chapter. A parcel map shall be required for subdivisions as to which a final or parcel map is not otherwise required by this chapter, unless the preparation of the parcel map is waived by local ordinance as provided in this section.

~~A parcel map shall not be required for either of the following:~~

(1) Subdivisions of a portion of the operating right-of-way of a railroad corporation, as defined by Section 230 of the Public Utilities Code, that are created by short-term leases (terminable by either party on not more than 30 days' notice in writing).

~~(2) Land conveyed to or from a governmental agency, public entity, public utility, or for land conveyed to a subsidiary of a public utility for conveyance to that public utility for rights-of-way, unless a showing is made in individual cases, upon substantial evidence, that public policy necessitates a parcel map. For purposes of this subdivision, land conveyed to or from a governmental agency shall include a fee interest, a leasehold interest, an easement, or a license.~~

~~(b) A local agency shall, by ordinance, provide a procedure for waiving the requirement for a parcel map, imposed by this division,~~ including the requirements for a parcel map imposed by Section 66426. The procedure may include provisions for waiving the requirement for a tentative and final map for the construction of a condominium project on a single parcel. The ordinance shall require a finding by the legislative body or advisory agency, that the proposed division of land complies with requirements established by this division or local ordinance enacted pursuant thereto as to area, improvement and design, floodwater drainage control, appropriate improved public roads, sanitary disposal facilities, water supply availability, environmental protection, and other requirements of this division or local ordinance enacted pursuant thereto. In any case, where the requirement for a parcel map is waived by local ordinance pursuant to this section, a tentative map may be required by local ordinance.

(c) If a local ordinance does not require a tentative map where a parcel map is required by this division, the subdivider shall have the option of submitting a tentative map, or if he or she desires to obtain the rights conferred by Chapter 4.5 (commencing with Section 66498.1), a vesting tentative map.

Mendocino County Code:

Sec. 17-17. Subdivision.

(A) Definition. "Subdivision" is the division of land as defined by California Government Code Section 66424 (Subdivision Map Act).

(B) Exclusions. "Division of Land" does not include, nor shall this Chapter apply to:

- (1) The financing or leasing of apartments, offices, stores, or similar space within an apartment building, industrial building, commercial building, mobile home park, or trailer park;
- (2) Mineral, oil, or gas leases;
- (3) Land dedicated for cemetery purposes under the Health and Safety Code of the State of California;
- (4) The conveyance or transfer of any interest therein to the United States, to the State of California, to the County of Mendocino, or to any city, school district, special district, or public utility;
- (5) A boundary line adjustment which has been approved by the Subdivision Committee and which meets the definition of such as expressly set forth in this Chapter;
- (6) The conveyance, transfer, creation, or establishment of an easement for sewer, water, or gas pipelines and appurtenance, or electrical or telephone poles and lines and appurtenances, or drainage, or private road purposes except when such private road easements are created by a subdivider over lands he has previously divided and said easements did not appear on the tentative map thereof;
- (7) A lot or parcel of land released from a deed of trust where the owner of record remains unchanged; for the purpose of this exception, the division of land shall be deemed to occur upon a sale of such parcel or parcels to others than the parties to the Deed of Trust;
- (8) The transfer of land or any interest therein by a deed which expressly restricts the use of the land to the construction, maintenance, and operation of a public utility; and
- (9) A boundary line agreement entered into for the purpose of, and having the sole legal effect of, clearly establishing the common boundary line or lines between two or more contiguous property owners, said boundary line, or lines, having heretofore been uncertain as to physical location.

Highlighting, above, is mine. I believe, as does Howard, that this covers us very well indeed. Not a bad idea to be sure, however.

Granville